

Chapter 19.11. Lighting

Sections:

[19.11.01. Purpose.](#)

[19.11.02. Applicability.](#)

[19.11.03. Definitions.](#)

[19.11.04. Temporary Lighting.](#)

[19.11.05. Lighting Standards and Design Requirements.](#)

[19.11.06. Lighting Plan.](#)

[19.11.07. Other Prohibited Lighting.](#)

[19.11.08. Maintenance of Nonconforming Lighting.](#)

19.11.01. Purpose.

1. These provisions are intended to ensure a high quality and sustainable environment in the City, through the application of minimum standards for and limitations on artificial lighting and glare, while protecting the public health, safety, and general welfare.
2. These lighting standards are also intended to control the use of outdoor artificial lighting and illumination to:
 - a. Protect drivers, residents, and pedestrians from the glare of non-vehicular light sources; and
 - b. Promote energy-efficient lighting design and operation; and
 - c. Protect and retain the intended visual character of the City; and
 - d. Minimize detrimental effects on the community character; and
 - e. Prevent undesirable light rays from intruding on private properties; and
 - f. Allow reasonable enjoyment of adjacent and nearby property by their owners and occupants; and
 - g. Increase nighttime safety, utility, security, and productivity.

(Ord. 14-23-1)

19.11.02. Applicability.

1. Conformance required: this section applies to all new development in the City unless otherwise exempted in this Title, expansions to previously existing development in the City, and uses proposed to operate during hours of darkness.
2. Exemptions: the following uses shall be exempt from the requirements of this section:
 - a. Agricultural Use: this regulation shall not be used to regulate any operational aspect of an agricultural use, including the cultivation and harvesting of crops, land management activities (controlled burning, clearing, spraying, trimming), livestock management, hunting, or use and application of water. This ordinance shall apply to the installation of new permanent lighting fixtures on building and structures.

- b. Emergency Lighting: all temporary emergency lighting needed by the police, fire department, or other emergency services.
- c. Vehicular lighting: lighting required by law to be installed on motor vehicles.
- d. Aircraft lighting: lighting required for the safe operation of aircraft.
- e. Construction lighting: construction lighting during the period of construction for which a development permit has been issued is exempt, provided such lighting is temporary and discontinued immediately upon completion of the construction work; also outdoor lighting employed during emergency night-time repair of roads and utilities.
- f. Existing nonconforming lighting fixtures: all outdoor light fixtures lawfully installed prior to the adoption of this section, except that the subject lighting fixtures shall conform to the hours of operation.
- g. Decorative holiday lighting.

(Ord. 14-23-1)

19.11.03. Definitions.

As used in these regulations, the following terms shall be defined as follows:

1. **Building Lighting** – lighting cast onto the walls of a building or structure.
2. **Business** – A person, partnership, corporation, or organization engaged in commerce, manufacturing, or a service; profit and non-profit seeking enterprise or concern; charitable organization. The definition is intended to be broadly construed.
3. **Digital Sign** – Cathode ray tube (CRT), flat panel liquid-crystal display (LCD), LED, plasma, aerial imaging, projector or other electronic device that electronically provides signage.
4. **Direct Light** – Light emitted directly from the lamp, off of the reflector diffuser, or through the refractor or diffuser lens of a lighting fixture.
5. **Fixture** – See “Lighting, Fixture”
6. **Fixture Height** – The location of the fixture as measured from the grade directly below the fixture to the top of the fixture.
7. **Foot-candle (fc)** – A unit of light measurement equal to one lumen per square foot.
8. **Full Cutoff** – Describes a lighting distribution where no light is allowed to emit from a light source at 90 degrees (horizontal plane) and all angles above. This applies to all horizontal angles around the lighting source, with no more than 10 percent of the light penetrating zone 1, and no light penetrating zone 2, as shown in Exhibit 1. A full cutoff lighting fixture is also fully shielded.

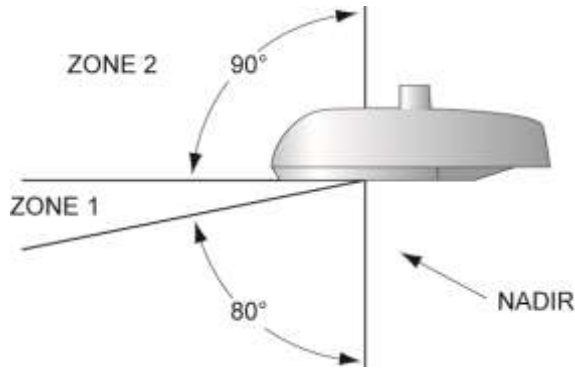

Exhibit 1

9. **Fully Shielded** – A lighting fixture constructed in such a manner that all light emitted by the source, either directly from the lamp or a diffusing element, or indirectly by reflection or refraction from any part of the lighting fixture, is projected below the horizontal plane, and where the lamp is not visible to the eye from a distance of 100 feet. A fully shielded fixture is not necessarily full cutoff.
10. **Glare** – Light emitting from a light source with intensity great enough to cause loss in visual performance or annoyance, so as to jeopardize health, safety, or welfare.
11. **Hazard to Air Navigation** – An obstruction or light source determined to have a substantial adverse effect on the safe and efficient utilization of the navigable airspace.
12. **Intermittent Lighting** – Lighting that does not remain on for more than ten minutes at a time.
13. **Lamp** – A bulb, globe, LED, cathode, beacon, or other source of light.
14. **Lighting Assembly** – A complete structure consisting of a fixture and lamp or lamps together with the parts designed to distribute the light, to support the lamps, to position and protect the lamps, to attach the lamps to the ground or to a structure, and to connect the lamps to a power supply.
15. **Lighting Fixture** – Luminaire, typically the housing, shade, and bulb portion of a lighting assembly
16. **Lumen** – A unit of measure for the brilliance of light source. The lumen rating associated with a given lamp is generally indicated on its packaging or may be obtained from the manufacturer.
17. **Nadir** – The direction pointing vertically down from the lowest light emitting part of the lighting fixture (see Exhibit 1 for an example).
18. **Nonconforming Lighting** – Any lighting that does not comply with the provisions of this Ordinance or with the provisions of any other applicable regulations of the City, but was lawfully pre-existing as of the effective date of this Ordinance or other applicable regulations.

19. **Outdoor Lighting** – Illumination of an outside area or object by any manmade device.
20. **Sport Lighting** – Lighting with the sole purpose of lighting a public sports field, court, or stadium during sporting events and training.
21. **Temporary Outdoor Lighting** – Lighting allowed as specified in an approved temporary permit pursuant to the requirements of this Chapter.
22. **Trespass Lighting** – Light emitted by a lighting fixture which is cast outside the boundaries of the property on which the lighting fixture is sited.
23. **Walkway Lighting** – Light which is intended to specifically illuminate a walkway or path, and does not include light that reaches a walkway from another source, such as a parking lot or street light.

(Ord. 14-23-1)

19.11.04 Temporary Lighting:

Any individual may submit a written request to the Planning Director for temporary lighting and obtain a temporary electrical permit for such lighting subject to the standards below.

1. The permit may allow temporary lighting for a period not to exceed ninety consecutive days, with at least ninety days passing before another temporary electrical permit may be issued for that same property.
2. The total period of all such permits issued for a single property may not exceed ninety days in any year.
3. The ability to acquire a temporary permit shall not in any way annul or eliminate any requirement to apply for and receive other permits or approvals which may be required by the City, or other applicable jurisdiction(s).
4. The request for temporary lighting must contain the following information in addition to information required to obtain a temporary electrical permit:
 - a. Proposed use, purpose and location of the outdoor light requested.
 - b. A written explanation of why compliance cannot be achieved.
 - c. Type of lamp(s) to be used, including manufacturer's part number and initial lumens.
 - d. Type of light fixture used, including manufacturer's model number and specification (cut) sheets indicating photometric distribution data stated in (ISO) foot-candle diagrams.
 - e. Starting and ending dates for temporary lighting use and identification of all prior temporary lighting permits requested or approved for the subject property
 - f. Contact information including name of applicant, affiliation (if applicable), address and telephone number.

- g. Such other information the Land Use Authority may require.
5. A permit application may be denied if it is determined that the nature, location, orientation, scale, length, intensity or other characteristic of such proposed temporary lighting will create a safety hazard, distraction to drivers, or otherwise have a negative impact on the public welfare.
 6. All temporary lighting proposed under this Ordinance shall to the maximum extent practical, limit the scale of proposed temporary exemptions (lumens, trespass, hours, etc.). In taking action on any such application, the Land Use Authority may deny in whole or in part, specific proposed elements of the proposal, or impose conditions and/or modifications in order to mitigate, reduce or eliminate potential negative impacts on the public health, safety or general welfare.

(Ord. 14-23-1)

19.11.05. Lighting Standards and Design Requirements.

The use of any materials or methods of installation not specifically described in this Section are prohibited.

1. **General Standards:** the standards below shall apply to all new lighting:
 - a. Material: all lighting fixtures and assemblies shall be metal.
 - b. Base: all lighting poles shall have a decorative base with a minimum height of sixteen inches, installed so as to conceal bolts, wires, and other structural attachments.
 - c. Type: all lighting fixtures shall be of the full cutoff variety, where no more than 10 percent of the total lumen output of the fixture will come out at 90° above the horizontal plane of the fixture from nadir. The fixture must shield the lamp in such a way that there will be total cutoff when viewed from 100' or more from the light source.
 - i. Shoebox fixtures are prohibited.
 - d. Angle: all fixtures, except any lighting specifically exempted in this Chapter, shall be directed downward.
 - i. For the lighting of predominately horizontal surfaces, fixtures shall be installed and aimed straight downward.
 - ii. For the lighting of predominately vertical surfaces, fixtures shall be installed and aimed downward in such a manner that light is not cast past the surface being illuminated, into the windows of neighboring residences, onto adjacent uses, onto public roadways, or skyward.
 - e. Lamp: any bulb type, including but not limited to LEDs, metal halide, and high-pressure sodium may be used, with the requirement that the color shall be soft white or amber. Bulbs exceeding 4000k in color temperature are prohibited, except that field lighting for sports fields shall not exceed 4200k in color temperature.

- f. Drawings: design and location of standards and fixtures shall be specified on the site development drawings.
- g. Flags: the United States flag and the state flag shall be permitted to be illuminated from dusk till dawn. All other flags shall not be illuminated past 11:00 p.m. Flag lighting sources shall not exceed 10,000 lumens per flagpole. The light source shall have a beam spread no greater than necessary to illuminate the flag.

2. Residential Lighting:

- a. All residential development:
 - i. Floodlights are prohibited, with the exception that intermittent security lighting is permitted. Such security lighting shall be directed so that light does not trespass onto adjacent property and may be activated by motion sensor or other security system.
 - ii. Street and parking lot pole lighting fixtures and assemblies shall be metal.
 - iii. Street and parking lot pole lighting fixtures and assemblies shall be black.
 - iv. Street and parking lot pole lighting assemblies shall include an arm and bell shade, or a pole and lantern configuration as outlined in the Technical Standards and Specification Manual.
 - v. Building lighting shall be full cutoff and downward directed, and only for the illumination of vertical surfaces such as building facades and signs, and shall not cast illumination beyond the surface being illuminated.
- b. Single Family:
 - i. Homes located less than one half mile from Camp Williams are exempt from the general design standards except that all lighting shall be full cutoff and shall not exceed 90 watts, and no upward lighting including landscape lighting is permitted.
 - ii. Homes located more than one half mile from Camp Williams, are exempt from the design standards except that all lighting shall be full cutoff.

3. Nonresidential Lighting:

- a. All wall-mounted fixtures shall not be mounted above 16'. The exception shall be those instances where there is a second story access directly from the outdoors, and under-eave lighting. Wall-mounted lighting shall be only for the illumination of vertical surfaces such as building facades and signs, and shall not cast illumination beyond the surface being illuminated.
- b. Intermittent lighting must be of the "motion sensor" type that stays on for a period of time not to exceed ten minutes and has a sensitivity setting that allows the lighting fixture to be activated only when motion is detected on the site.
- c. All trespass lighting shall not exceed one foot-candles measured at the property line, except that trespass lighting into residential development shall not exceed 0.1 foot-candles measured at the property line.
- d. Service station canopies must utilize canopy lights that are fully recessed into the canopy or are fully shielded by the canopy.
- e. All freestanding lighting fixtures and assemblies shall be black.

- i. Regional Parks may include theme lighting fixtures in colors other than black. The color shall enhance the theme of the park and shall be approved during the site plan review process.
- f. Pole design shall include an arm and bell shade.
 - i. Regional Parks may include theme lighting fixtures that do not include an arm and bell shade. The design shall enhance the theme of the park and shall be approved during the site plan review process.
- g. Parking lot poles shall be limited to a height of 16' when in or within 200' of a residential zone; all other locations shall have a height limit of 20'.
- h. All lighting fixtures in surface parking lots and on the top decks of parking structures shall be fitted to render them full cutoff.
- i. Hours:
 - i. One hour after closing or by 11:00 p.m., whichever is earlier, businesses must turn off at least fifty percent of building lighting and lighting fixtures in surface parking lots and on top decks of parking structures; however, those lighting fixtures turned off may be set to function utilizing a motion detector system. Lights may be turned back on one half hour prior to the first employee shift.
 - ii. Business open for 24 hours must turn off 50 percent of their outdoor and parking lot lighting by 11:00 p.m. and must keep them off until one half hour before sunrise, however, those lighting fixtures turned off may be set to function utilizing a motion detector system.

4. Outdoor Sign Lighting

- a. All illuminated signs located within one-half mile of Camp W.G. Williams shall be positioned in such a manner and contain shielding devices as to significantly reduce spillover light affecting the military installation and operations. In no instance shall signs within one-half mile be positioned facing parallel to the adjacent boundaries of Camp W.G. Williams.
- b. On-premise signs may remain illuminated during regular business hours, but may not be illuminated later than one-half hour after the business is no longer open to the public, nor prior to the daily opening of the business to the public.
- c. External illumination for wall signs shall be positioned in a downward direction directly onto the sign in such a manner that light does not project past the sign surface being illuminated.
- d. Monument signs may have upward illumination provided the light source is not visible, and the fixtures shall be installed and aimed in such a manner that light is not projected past the sign surface being illuminated, into the windows of neighboring residences, onto adjacent uses, onto public roadways, or skyward.
- e. Internally illuminated signs shall be designed so that the light source is not visible.
- f. See Chapter 19.18 for additional requirements.
- g. Nothing in this section shall be interpreted to authorize signs in areas of the City prohibiting signs.

5. Sports Lighting:

- a. Field and stadium lighting fixtures shall not be mounted at a height greater than 80' and shall be directed inward and downward at an angle not to exceed 45 degrees.

6. Walkway lighting:

- a. Lighting of all pedestrian pathways is recommended.
- b. All pathway, walkway, and sidewalk lighting fixtures shall be mounted at a height not to exceed 10 feet.
 - i. Themed walkway lighting within Regional Parks shall not exceed a height of 25 feet. Such lighting within 200 feet of residential development shall not exceed 16 feet.
- c. Bollard lighting shall be limited to a height of 4 feet.

7. Street Lighting:

- a. All parking lot light fixtures shall be installed in locations so that glare or excessive direct light will not adversely affect adjacent properties.
- b. All light fixtures and assemblies shall be black.
- c. Pole mounted fixtures are required for street lighting and shall meet the City standard.

(Ord. 17-26, Ord. 17-14, Ord. 14-23-1)

19.11.06. Lighting Plan.

A lighting plan shall be submitted as part of any subdivision, site plan, building permit, or other applicable development application that will include artificial illumination. This plan shall include the following:

1. Plans indicating the location and types of illuminating devices on the premises.
2. Descriptions of the illuminating devices, fixtures, lamp supports, and other devices. This description may include, but is not limited to, manufacturers' specifications, drawings, and sections.
3. Photometric sheet showing measurement of light intensity across the site and onto adjacent property in terms of candela, lumens, and foot-candles.
4. Plans providing information required in the Technical Standards and Specifications Manual.

(Ord. 21-14, Ord. 14-23-1)

19.11.07. Other Prohibited Lighting

Unless expressly permitted elsewhere in this Title, the following are prohibited:

1. The use of laser source light or any similar high intensity light, such as used for outdoor advertising or entertainment, when projected above the horizontal plane is prohibited; and
2. The use of strobe lights is prohibited.
3. The operation of searchlights, except by authorized public safety officials, for any purposes is prohibited.

(Ord. 14-23-1)

19.11.08. Maintenance of Nonconforming Lighting

1. All lighting fixtures and assemblies lawfully in place and operating prior to the effective date of this ordinance shall have legal nonconforming status.
2. Minor repair and maintenance of legal nonconforming lighting fixtures and assemblies is allowed. Replacement of a sign shall terminate nonconforming status of that fixture and at that time, all standards of this regulation must be met.

(Ord. 14-23-1)